

CHAPTER 12

Surface Areas and Volumes

VEDA
ACADEMY

CLASS 10TH

NCERT EXERCISE AND SOLUTIONS - MATHEMATICS

EXERCISE 12.1

1. 2 cubes each of volume 64 cm^3 are joined end to end. Find the surface area of the resulting cuboid.

SOLUTION:

The diagram is given as:

Given,

The Volume (V) of each cube is $= 64 \text{ cm}^3$

This implies that $a^3 = 64 \text{ cm}^3$

$\therefore a = 4 \text{ cm}$

Now, the side of the cube $= a = 4 \text{ cm}$

Also, the length and breadth of the resulting cuboid will be 4 cm each, while its height will be 8 cm .

So, the surface area of the cuboid $= 2(lb + bh + lh)$

$$= 2(4 \times 4 + 4 \times 8 + 4 \times 8) \text{ cm}^2$$

$$= 2(16 + 32 + 32) \text{ cm}^2$$

$$= (2 \times 80) \text{ cm}^2 = 160 \text{ cm}^2$$

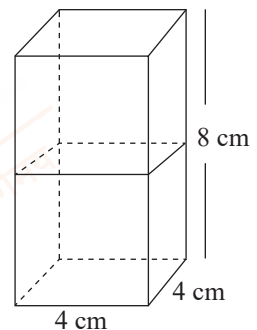

2. A vessel is in the form of a hollow hemisphere mounted by a hollow cylinder. The diameter of the hemisphere is 14 cm , and the total height of the vessel is 13 cm . Find the inner surface area of the vessel.

SOLUTION:

The diagram is as follows:

Now, the given parameters are:

The diameter of the hemisphere $= D = 14 \text{ cm}$

The radius of the hemisphere $= r = 7 \text{ cm}$

Also, the height of the cylinder $= h = (13 - 7) = 6 \text{ cm}$

Now, the inner surface area of the vessel $= \text{CSA of the cylindrical part} + \text{CSA of the hemispherical part}$

$$(2\pi rh + 2\pi r^2) \text{ cm}^2 = 2\pi r(h + r) \text{ cm}^2$$

$$2 \times \frac{22}{7} \times 7(6 + 7) \text{ cm}^2 = 572 \text{ cm}^2$$

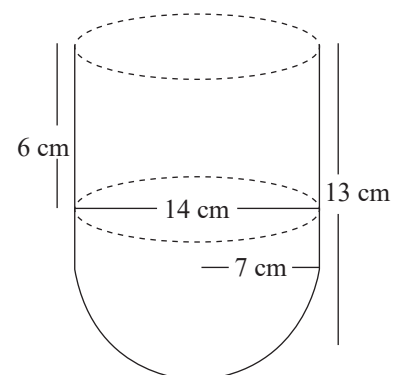

3. A toy is in the form of a cone of radius 3.5 cm mounted on a hemisphere of the same radius. The total height of the toy is 15.5 cm. Find the total surface area of the toy.

SOLUTION:

The diagram is as follows:

Given that the radius of the cone and the hemisphere (r) = 3.5 cm or $\frac{7}{2}$ cm

The total height of the toy is given as 15.5 cm.

So, the height of the cone (h) = $15.5 - 3.5 = 12$ cm

Slant height of the cone

$$l = \sqrt{h^2 + r^2}$$

$$\Rightarrow l = \sqrt{12^2 + \frac{7^2}{2^2}}$$

$$\Rightarrow l = \sqrt{144 + \frac{49}{4}} = \sqrt{\frac{576 + 49}{4}} = \sqrt{\frac{625}{4}}$$

$$\Rightarrow l = \frac{25}{2}$$

\therefore The curved surface area of the cone = $\pi r l$

$$= \frac{22}{7} \times \frac{7}{2} \times \frac{25}{2} = \frac{275}{2} \text{ cm}^2$$

Also, the curved surface area of the hemisphere = $2\pi r^2$

$$= 2 \times \frac{22}{7} \times \frac{7^2}{2^2}$$

$$= 77 \text{ cm}^2$$

Now, the total surface area of the toy = CSA of the cone + CSA of the hemisphere

$$= \frac{275}{2} + 77 \text{ cm}^2$$

$$= \frac{275 + 154}{2} \text{ cm}^2$$

$$= \frac{429}{2} \text{ cm}^2 = 214.5 \text{ cm}^2$$

Hence the total surface area (TSA) of the toy is 214.5 cm^2

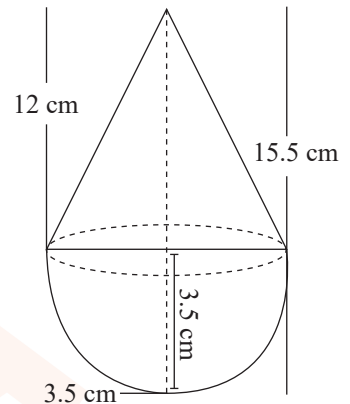

4. A cubical block of side 7 cm is surmounted by a hemisphere. What is the greatest diameter the hemisphere can have? Find the surface area of the solid.

SOLUTION:

It is given that each side of the cube is 7 cm. So, the radius will be $\frac{7}{2}$ cm.

We know,

The total surface area of solid (TSA) = Surface area of the cubical block + CSA of the hemisphere – Area of the base of the hemisphere

$$\therefore \text{TSA of solid} = 6 \times (\text{side})^2 + 2\pi r^2 - \pi r^2$$

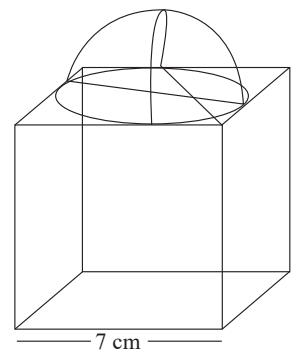

$$\begin{aligned}
 &= 6 \times (\text{side})^2 + \pi r^2 \\
 &= 6 \times (7)^2 + \frac{22}{7} \times \frac{7}{2} \times \frac{7}{2} \\
 &= (6 \times 49) + \frac{77}{2} \\
 &= 294 + 38.5 = 332.5 \text{ cm}^2
 \end{aligned}$$

So the surface area of the solid is 332.5 cm^2

- 5. A hemispherical depression is cut out from one face of a cubical wooden block such that the diameter l of the hemisphere is equal to the edge of the cube. Determine the surface area of the remaining solid.**

SOLUTION:

The diagram is as follows:

Now, the diameter of the hemisphere = Edge of the cube = l

So, the radius of the hemisphere = $\frac{l}{2}$

\therefore The total surface area of solid = Surface area of cube + CSA of the hemisphere – Area of the base of the hemisphere

The surface area of the remaining solid = $6(\text{edge})^2 + 2\pi r^2 - \pi r^2$

$$\begin{aligned}
 &= 6l^2 + \pi r^2 \\
 &= 6l^2 + \pi \frac{l^2}{2^2} \\
 &= 6l^2 + \frac{\pi l^2}{4} \\
 &= \frac{l^2}{4} (24 + \pi) \text{ sq. units}
 \end{aligned}$$

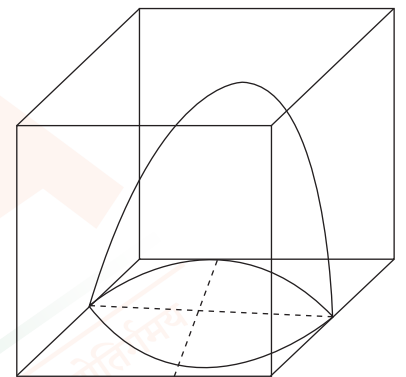

- 6. A medicine capsule is in the shape of a cylinder with two hemispheres stuck to each of its ends. The length of the entire capsule is 14 mm, and the diameter of the capsule is 5 mm. Find its surface area.**

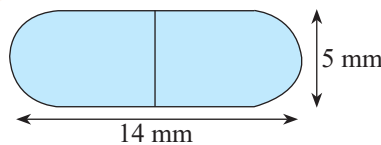

SOLUTION:

Two hemispheres and one cylinder are shown in the figure given below.

Here the diameter of the capsule = 5 mm

\therefore Radius = $\frac{5}{2} = 2.5 \text{ mm}$

Now, the length of the capsule = 14 mm

So, the length of the cylindrical part = $14 - (2.5 + 2.5) = 9 \text{ mm}$

\therefore The surface area of a hemisphere = $2\pi r^2 = 2 \times \frac{22}{7} \times 2.5 \times 2.5$

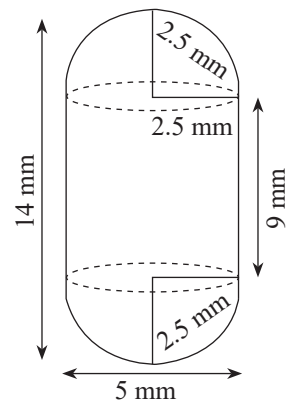

$$= \frac{275}{7} \text{ mm}^2$$

Now, the surface area of the cylinder = $2\pi rh$

$$= 2 \times \frac{22}{7} \times 2.5 \times 9$$

$$\frac{22}{7} \times 45 = \frac{990}{7} \text{ mm}^2$$

Thus, the required surface area of the medicine capsule will be

$$= 2 \times \text{CSA of hemisphere} + \text{CSA of the cylinder}$$

$$= 2 \times \frac{275}{7} + \frac{990}{7}$$

$$= \frac{550}{7} + \frac{990}{7} = \frac{1540}{7} = 220 \text{ mm}^2$$

7. A tent is in the shape of a cylinder surmounted by a conical top. If the height and diameter of the cylindrical part are 2.1 m and 4 m, respectively, and the slant height of the top is 2.8 m, find the area of the canvas used for making the tent. Also, find the cost of the canvas of the tent at the rate of ₹500 per m^2 . (Note that the base of the tent will not be covered with canvas.)

SOLUTION:

It is known that a tent is a combination of a cylinder and a cone.

From the question, we know that

Diameter = 4 m

The slant height of the cone (l) = 2.8 m

Radius of the cone (r) = Radius of cylinder = $\frac{4}{2} = 2$ m

Height of the cylinder (h) = 2.1 m

So, the required surface area of the tent = CSA of the cone + CSA of the cylinder

$$= \pi rl + 2\pi rh$$

$$= \pi r(l + 2h)$$

$$= \frac{22}{7} \times 2(2.8 + 2 \times 2.1)$$

$$= \frac{44}{7} \times (2.8 + 4.2)$$

$$= \frac{44}{7} \times 7 = 44 \text{ m}^2$$

∴ The cost of the canvas of the tent at the rate of ₹500 per m^2 will be

$$= \text{Surface area} \times \text{Cost per m}^2$$

$$44 \times 500 = ₹22000$$

Hence, ₹22000 will be the total cost of the canvas.

8. From a solid cylinder whose height is 2.4 cm and diameter is 1.4 cm, a conical cavity of the same height and same diameter is hollowed out. Find the total surface area of the remaining solid to the nearest cm^2 .

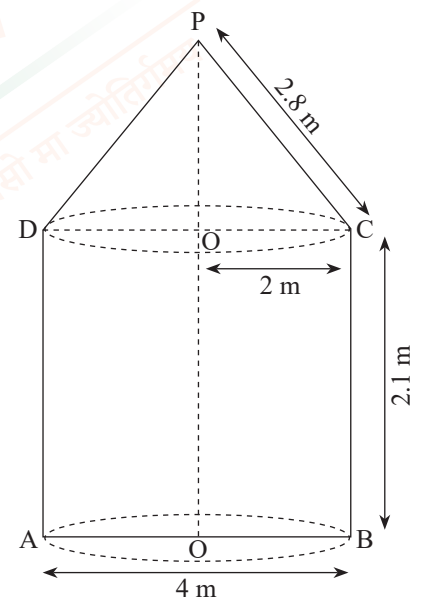

SOLUTION:

From the question, we know the following:

The diameter of the cylinder = diameter of conical cavity = 1.4 cm

So, the radius of the cylinder = radius of the conical cavity = $\frac{1.4}{2} = 0.7$

Also, the height of the cylinder = height of the conical cavity = 2.4 cm

∴ Slant height of the conical cavity (l) = $\sqrt{h^2 + r^2}$

$$\begin{aligned} &= \sqrt{(2.4)^2 + (0.7)^2} \\ &= \sqrt{5.76 + 0.49} = \sqrt{6.25} \\ &= 2.5 \text{ cm} \end{aligned}$$

Now, the TSA of the remaining solid = CSA of conical cavity + TSA of the cylinder

$$\begin{aligned} &= \pi r l + (2\pi r h + \pi r^2) \\ &= \pi r (l + 2h + r) \\ &= \frac{22}{7} \times 0.7 (2.5 + 4.8 + 0.7) \\ &= 2.2 \times 8 = 17.6 \text{ cm}^2 \end{aligned}$$

Hence, the total surface area of the remaining solid is 17.6 cm²

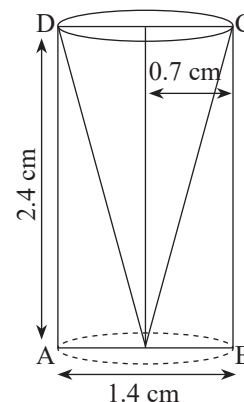

EXERCISE 12.2

1. A solid is in the shape of a cone standing on a hemisphere, with both their radii being equal to 1 cm and the height of the cone being equal to its radius. Find the volume of the solid in terms of π .

SOLUTION:

Here $r = 1$ cm and $h = 1$ cm.

Now, Volume of solid = Volume of conical part + Volume of hemispherical part

We know the volume of cone = $\frac{1}{3} \pi r^2 h$

And,

The volume of the hemisphere = $\frac{2}{3} \pi r^3$

So, the volume of the solid will be = $\frac{1}{3} \pi r^2 h + \frac{2}{3} \pi r^3 = \frac{1}{3} \pi r^2 (h + 2r)$

$$\begin{aligned} &= \frac{1}{3} \pi (1)^2 [1 + 2(1)] \text{ cm}^3 = \frac{1}{3} \pi \times 1 \times (3) \text{ cm}^3 \\ &= \pi \text{ cm}^3 \end{aligned}$$

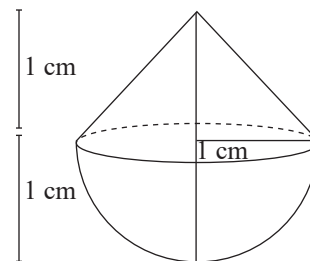

2. Rachel, an engineering student, was asked to make a model shaped like a cylinder with two cones attached at its two ends by using a thin aluminium sheet. The diameter of the model is 3 cm, and its length is 12 cm. If each cone has a height of 2 cm, find the volume of air contained in the model



that Rachel made. (Assume the outer and inner dimensions of the model are nearly the same.)

SOLUTION:

Given, Height of model = 12 cm

Height of cone = 2 cm

Height of cylinder = 12 - 4 = 8 cm

Radius = 1.5 cm

Now, the total volume of the air contained will be

= Volume of cylinder + 2 × (Volume of the cone)

$$\begin{aligned} \therefore \text{Total volume} &= \pi r^2 h + \left[2 \times \left(\frac{1}{3} \pi r^2 h \right) \right] \\ &= \pi (1.5)^2 \times 8 + 2 \times \frac{1}{3} \times \pi \times (1.5)^2 \times 2 \\ &= 18\pi + 2(1.5\pi) = \frac{22}{7} (18 + 3) = \frac{22}{7} \times 21 \\ &= 66 \text{ cm}^3 \end{aligned}$$

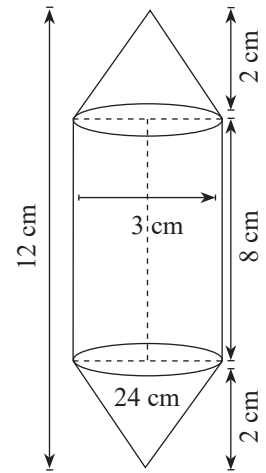

3. A gulab jamun contains sugar syrup up to about 30% of its volume. Find approximately how much syrup would be found in 45 gulab jamuns, each shaped like a cylinder with two hemispherical ends with a length of 5 cm and a diameter of 2.8 cm (see figure).

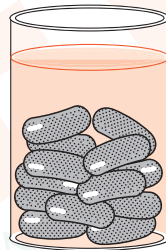

SOLUTION:

It is known that the gulab jamuns are similar to a cylinder with two hemispherical ends.

So, the total height of a gulab jamun = 5 cm.

Diameter = 2.8 cm

So, radius = 1.4 cm

\therefore The height of the cylindrical part = 5 cm - (1.4 + 1.4) cm = 2.2 cm

Now, the total volume of one gulab jamun

= Volume of cylinder + Volume of two hemispheres

$$\begin{aligned} &= \pi r^2 h + \frac{4}{3} \pi r^3 \\ &= \pi (1.4)^2 \times 2.2 + \frac{4}{3} \pi \\ &= 4.312\pi + \frac{10.976}{3} \pi \end{aligned}$$

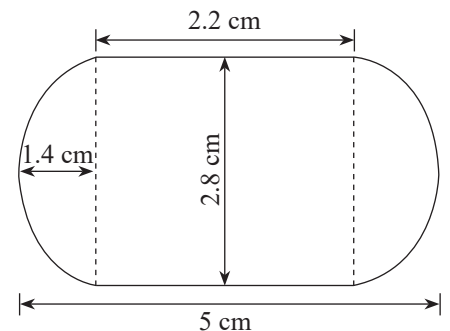

$$= 25.05 \text{ cm}^3$$

We know that the volume of sugar syrup = 30% of the total volume

So, the volume of sugar syrup in 45 gulab jamuns = $45 \times 30\%$ of 25.05 cm^3

$$= 45 \times 7.515 = 338.175 \text{ cm}^3$$

4. A pen stand made of wood is in the shape of a cuboid with four conical depressions to hold pens. The dimensions of the cuboid are 15 cm by 10 cm by 3.5 cm. The radius of each of the depressions is 0.5 cm, and the depth is 1.4 cm. Find the volume of wood in the entire stand (see Fig.).

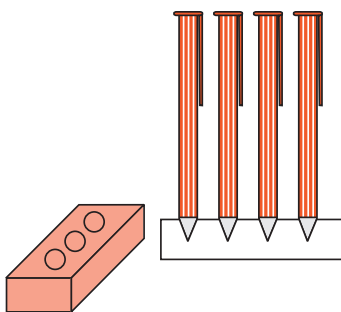

SOLUTION:

The volume of the cuboid = length \times width \times height

We know the cuboid's dimensions as 15 cm \times 10 cm \times 3.5 cm

So, the volume of the cuboid = $15 \times 10 \times 3.5 = 525 \text{ cm}^3$

Here, depressions are like cones, and we know,

$$\text{Volume of cone} = \frac{1}{3} \pi r^2 h$$

Given, radius (r) = 0.5 cm and depth (h) = 1.4 cm

$$\therefore \text{Volume of 4 cones} = 4 \times \frac{1}{3} \pi r^2 h = 4 \times \frac{1}{3} \times \frac{22}{7} \times 0.5 \times 0.5 \times 1.4$$

$$= 1.46 \text{ cm}^3$$

Now, the Volume of wood = Volume of the cuboid $- 4 \times$ Volume of the cone

$$= 525 - 1.46 = 523.54 \text{ cm}^3$$

5. A vessel is in the form of an inverted cone. Its height is 8 cm and the radius of its top, which is open, is 5 cm. It is filled with water up to the brim. When lead shots, each of which is a sphere of radius 0.5 cm, are dropped into the vessel, one-fourth of the water flows out. Find the number of lead shots dropped in the vessel.

SOLUTION:

For the cone,

Radius = 5 cm,

Height = 8 cm

Also,

Radius of Spherical lead shots = 0.5 cm

The diagram will be like

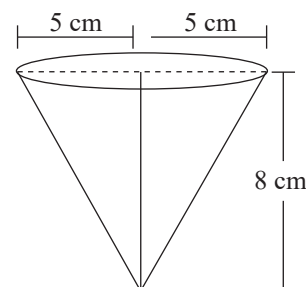

It is known that,

$$\text{Volume of cone} = \text{Volume of water in the cone} = \frac{1}{3} \pi r^2 h = \frac{1}{3} \times 5 \times 5 \times 8 \times \pi = \frac{200}{3} \pi \text{ cm}^3$$

$$\text{Now, total volume of water overflow} = \frac{1}{4} \times \frac{200}{3} \pi = \frac{50}{3} \pi$$

$$\text{The volume of Spherical lead shot} = \frac{4}{3} \times \frac{0.5}{10} \times \frac{0.5}{10} \times \frac{0.5}{10} \times \pi = \frac{1}{6} \pi$$

$$\text{The number of lead shots} = \frac{\text{Total Volume of water overflow}}{\text{Volume of Spherical lead shot}}$$

$$\begin{aligned} &= \frac{\frac{50}{3} \pi}{\frac{1}{6} \pi} \\ &= \frac{50}{3} \times 6 = 100 \end{aligned}$$

Hence, 100 spherical lead shots dropped in the vessel.

6. A solid iron pole consists of a cylinder of height 220 cm and base diameter 24 cm, which is surmounted by another cylinder of height 60 cm and radius 8 cm. Find the mass of the pole, given that 1 cm³ of iron has approximately 8 g mass.

SOLUTION:

Given the height of the big cylinder (H) = 220 cm

$$\text{The radius of the base (R)} = \frac{24}{2} = 12 \text{ cm}$$

So, the volume of the big cylinder = $\pi R^2 H$

$$\begin{aligned} &= \pi(12)^2 \times 220 \text{ cm}^3 \\ &= 99565.71 \text{ cm}^3 \end{aligned}$$

Now, the height of the smaller cylinder (h) = 60 cm

The radius of the base (r) = 8 cm

So, the volume of the smaller cylinder = $\pi r^2 h$

$$\begin{aligned} &= \pi(8)^2 \times 60 \text{ cm}^3 \\ &= 12068.57 \text{ cm}^3 \end{aligned}$$

∴ The Volume of pole = Volume of the big cylinder + Volume of the small cylinder

$$\begin{aligned} &= 99565.71 + 12068.57 \\ &= 111634.28 \text{ cm}^3 \end{aligned}$$

We know,

Mass = Density × Volume

$$\text{So, the mass of the pole} = 8 \times 111634.28 = 893074.248 \text{ g}$$

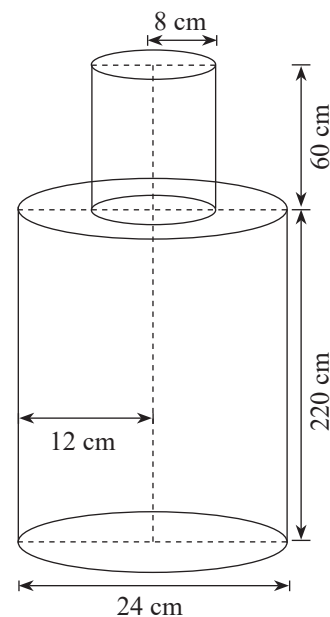

= 893 Kg (approx.)

7. A solid consisting of a right circular cone of height 120 cm and radius 60 cm standing on a hemisphere of radius 60 cm is placed upright in a right circular cylinder full of water such that it touches the bottom. Find the volume of water left in the cylinder if the radius of the cylinder is 60 cm and its height is 180 cm.

SOLUTION:

Radius of cone = 60 cm

Height of cone = 120 cm

Radius of cylinder = 60 cm

Height of cylinder = 180 cm

Radius of hemisphere = 60 cm

Now,

The total volume of solid = Volume of Cone + Volume of the hemisphere

$$\text{Volume of cone} = \frac{1}{3} \pi r^2 h = \frac{1}{3} \times \pi \times 60^2 \times 120 = 144000\pi \text{ cm}^3$$

$$\text{Volume of hemisphere} = \frac{2}{3} \times \pi \times 60^3 \text{ cm}^3 = 144 \times 10^3 \pi = 144000\pi \text{ cm}^3$$

$$\text{So, total volume of solid} = 28000\pi \text{ cm}^3$$

$$\text{Volume of cylinder} = \pi \times 60^2 \times 180 = 648000\pi = 648 \times 10^3 \pi \text{ cm}^3$$

Now, the volume of water left will be = Volume of the cylinder – Volume of solid

$$= (648 - 288) \times 10^3 \times \pi = 360 \times 10^3 \times \frac{22}{7} = 1131.43 \times 10^3 \text{ cm}^3 = 1.131 \text{ m}^3$$

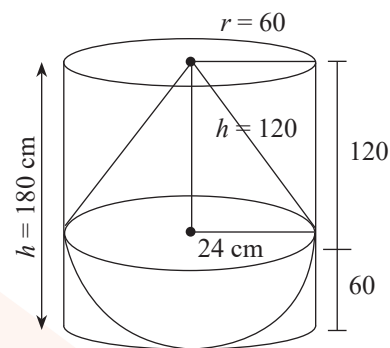

8. A spherical glass vessel has a cylindrical neck 8 cm long and 2 cm in diameter; the diameter of the spherical part is 8.5 cm. By measuring the amount of water it holds, a child finds its volume to be 345 cm³. Check whether she is correct, taking the above as the inside measurements and $\pi = 3.14$.

SOLUTION:

Given,

For the cylinder part, Height (h) = 8 cm

$$\text{and Radius (R)} = \frac{2}{2} \text{ cm} = 1 \text{ cm}$$

$$\text{For the spherical part, Radius (r)} = \frac{8.5}{2} = 4.25 \text{ cm}$$

Now, volume of this vessel = Volume of cylinder + Volume of sphere

$$= \pi \times (1)^2 \times 8 + \frac{4}{3} \pi (4.25)^3$$

$$= 8\pi + 102.35\pi = 110.35 \times 3.14$$

$$= 346.5 \text{ cm}^3$$

Hence, the child's calculation is not correct.

